

DUCT-M

"UNEL-MEC" MOTORNI KANALNI AKSIJALNI VENTILATOR

DUCTED AXIAL FAN - "IEC" MOTOR



APLIKACIJE

Ventilatori serije DUCT-M su idealni za aplikacije gde su potrebni veliki protok vazduha i relativno skromni pritisci, u aplikacijama sa fiksiranjem na kanale. Na primer: industrijski sistemi ventilacije i klimatizacije u rudarstvu, pomorskim aplikacijama, isparljivim tornjevima, izmenjivačima toplote, hlađenju električne opreme, frižiderima itd. Serija DUCT-M omogućava upotrebu aksijalnih ventilatora u prisustvu diskretnih pritisaka koristeći višestepenu verziju koja obezbeđuje dva ili više ventilatora kombinovanih u seriji, suprotno rotirajućim. Ovo rešenje omogućava oporavak rotacione komponente vazduha pretvaranjem u pritisak, razvijajući do 2,7 puta veći pritisak od jednog ventilatora sa istom geometrijom i brzinom.

DOMET

Serijski se sastoji od 15 veličina sa prečnikom radnog kola od 310 do 1600 mm.

KARAKTERISTIKE

DUCT-M seriju karakteriše ekstremna robusnost konstrukcije, u suštini zbog prirubnica dobijenih direktno iz školjke (a nisu prikazane), i debljine upotrebljenih materijala. Druga karakteristika je raznovrsnost verzija i modela od kojih je serija sastavljena, što omogućava odgovarajuće rešenje za brojne probleme ventilacije. Radno kolo ima čvrstu glavčinu stege, od livenog aluminijuma za fiksiranje lopatica. Lopate izrađene livenjem od različitih materijala uvek sa ciljem da izdrže velika opterećenja.

KONSTRUKCIJA

- Transporter od čeličnog lima zaštićen epoksidno-poliesterskom bojom. Prirubnice veličine prema UNI EN ISO 13351 / Tab.1.
- Radno kolo visokih performansi sa lopaticama profila krila, sa promenljivim uglom nagiba kada miruje, od tehnopolimera ili livenog aluminijuma, glavčina od livenog aluminijuma.
- BASinhroni elektromotor naizmjenične struje, IP 55 zaštita, CI F izolacija, S1 servis, oblik B3, konstrukcija u skladu sa specifičnim IEC/IEC (UNEL-MEC) standardima.
- Esecuzione 4 (accoppiamento diretto con girante a sbalzo).

TEHNIČKE SPECIFIKACIJE

DUCT-M STANDARD

- Vazduh koji se prenosi: čist ili malo prašnjav, neabrazivan.
- Temperatura transportovanog vazduha: 20°C / +50°C
- Napon napajanja: trofazna verzija (T) 400V- 3 Ph - 50Hz
monofazna verzija (M) 230-1Ph - 50Hz
- Protok vazduha od motora do radnog kola, položaj A (FMG)

VERZIJE

- DUCT Mm:** srednji transporter: jedinica motora / radnog kola skoro potpuno uključena u dužinu kućišta
- DUCT-MI:** dugačak transporter. Jedinica motora / radnog kola u potpunosti "uključena" u dužinu kućišta.
- DUCT-Ms:** kratki transporter. Motor viri iz kućišta i dostupan je.

PRIBOR

- Usisni usnik (IN).
- Prigušivači (SILDU).
- Ravna (FPGDU) i konusna (CPGDU) (sigurnosna mreža (neophodna za upotrebu sa slobodnim ustima).
- Inspeksijski otvor.
- Antivibracioni spoj (FCDU).
- Antivibracioni nosači (AV).
- Kontra prirubnica (CFDU).
- Eksterni terminalni blok (OTB).
- Noge za fiksiranje (FF-DU).
- Servisni prekidač (SV).

NA ZAHTEV

- Usluge koje nisu prikazane
- Verzije sa radnim kolom sa aluminijumskim lopaticama.
- Verzije sa "efikasno" reverzibilnim protokom vazduha (DUCT-REV).
- Atek verzije (DUCT ATEKS).
- Višestepene verzije (DUCT-CT).
- Verzije za isparenja od požara (DUCT-HT)
- Verzije sa transporterom od nerđajućeg čelika ili aluminijuma ili toplo pocinkovanog lima.
- Verzije sa protokom vazduha od radnog kola do motora, pozicija B (FGM).

APLIKACIONE

DUCT- M line is suitable when large air capacities with relatively low pressures are required in duct mounted applications. For instance: ventilation and conditioning in naval and mining applications, evaporative towers, heat exchangers, cooling of electric and refrigerating equipments, etc. With this line is possible to attain higher pressures using the multistage version consisting of two single stages fans mounted in series, with contra-rotating impellers. This solution allows the recovery of the air rotative component turning it in pressure, developing up to 2.7 times the pressure of a single fan having the same geometry and speed.

RANGE

This line consists of 15 sizes with impeller diameter from 310 up to 1600 mm.

ADVANTAGES

DUCT- M line is characterised by the extreme sturdiness of construction, thanks to the flanges directly bended on the casing, and the thickness of the materials. The variety of versions and models allows the solution of most of the problems of ventilation. Impeller consists of a strong hub, in die-cast aluminum alloy for the fixing of the blades. Available in different materials suitable for heavy duties.

CONSTRUCTION

- Casing in steel sheet protected with epoxy painting. Fixing flanges according to UNI EN ISO 13351/Tab.1 standards.
- Impeller with high efficiency airfoil blades in plastic material or in die-cast aluminum alloy. Hub in die-cast aluminum alloy. Balancing according to UNI ISO 21940-11. Variable pitch angle in still position.
- Asynchronous electric motor, protection IP 55, class F insulated, form B3, service S1 construction according to the IEC/IEC (UNEL-MEC) standard.
- Arrangement 4 (impeller directly coupled to motor shaft).

TECHNICAL SPECIFICATIONS

- DUCT- M standard
- Conveyed air: clean, not abrasive.
- Temperature of conveyed air: -20°C/+50°C.
- Voltage: three phase version (T) 400V-3Ph.
Single phase version (M) 230V-1Ph.
- Frequency: 50Hz.
- Air flow from motor to impeller, position A (FMG).

VERSIONS

- DUCT-Mm:** medium length casing: motor/impeller assembly almost completely enclosed within the length of the casing.
- DUCT-MI:** long casing. Impeller and motor are completely enclosed within the overall length of the casing.
- DUCT-Ms:** short casing. Motor partially protrudes beyond the rear mounting flange.

ACCESSORIES

- Inlet nozzle (IN).
- Silencers (SIL-DU).
- Flat protection grid (FPG-DU) and conic (CPG-DU) (Necessary for use in free air)
- Inspection door.
- Flexible connection (FC-DU).
- Antivibration mounts (AV).
- Counter flange (CF-DU).
- Outer terminal box (OTB).
- Fixing feet (FF-DU).
- Service switch (SW).

ON REQUEST

- Performances differing from standard
- Versions with impeller with in die-cast aluminum blades
- Versions with true reversible airflow (DUCT-REV).
- Explosion proof versions (DUCT ATEX).
- Multistage system versions (DUCT-CT).
- Smoke exhaust version (DUCT HT)
- Versions with casing in stainless steel, aluminum, or hot dip galvanised steel.
- Versions with air flow from impeller to motor, position B (FGM).

DUCT-M

PERFORMANSE - PERFORMANCES

1 mm H₂O = 9,8 Pa

Performanse prikazane na dijagramima odnose se na vazduh na temperaturi od 15 °C i nadmorskoj visini od 0 m., a dobijeni su u instalacijama tipa "D" u nedostatku mreže i pribora.

Performance shown in the selection diagrams refer to the airflow from impeller to air at 15°C temperature and 0 mt a.s.l. altitude, and they were obtained in installation type "D" with no grid nor accessories.

2 POLA / POLES (3000 RPM) MONOFAZNA / SINGLE-PHASE (1Ph-230V 50Hz)

Modello Model	Portata Flow rate (m ³ /h)	Pm (kW)	In max (A)	Mot. (H)	Lp (dB(A))	Kg
312/A M	3.500	0,25	1,7	63	70	17
352/A M *	5.100	0,55	4	71	74	20
402/A M *	8.200	1,1	8	80	79	27

4 POLA / POLES (1500 RPM) MONOFAZNA / SINGLE-PHASE (1Ph-230V 50Hz)

Modello Model	Portata Flow rate (m ³ /h)	Pm (kW)	In max (A)	Mot. (H)	Lp (dB(A))	Kg
314/A M	2.300	0,09	1	56	52	15
354/A M	3.200	0,09	1	56	56	16
404/A M *	4.000	0,12	1,1	63	61	18
404/B M *	5.200	0,18	1,4	63	62	19
454/A M *	6.500	0,25	1,8	71	65	23
454/B M *	7.600	0,37	3,3	71	66	24

2 POLA / POLES (3000 RPM) TROFAZNA / THREE-PHASE (3Ph-230V 50Hz)

Modello Model	Portata Flow rate (m ³ /h)	Pm (kW)	In max (A)	Mot. (H)	Lp (dB(A))	Kg
312/A T	3.500	0,25	0,7	63	70	17
352/A T	5.100	0,55	1,6	71	74	20
402/A T	8.200	1,1	2,6	80	79	27

6 POLA / POLES (1000 RPM) TROFAZNA / THREE-PHASE (3Ph-400V 50Hz)

Modello Model	Portata Flow rate (m ³ /h)	Pm (kW)	In max (A)	Mot. (H)	Lp (dB(A))	Kg
506/A T *	6.000	0,18	0,7	71	58	27
566/A T	8.500	0,25	1	71	62	34
636/A T	12.500	0,37	1,3	80	66	40
636/B T	14.000	0,75	2,2	90	65	46
716/A T	16.000	0,75	2,2	90	67	53
716/B T	17.000	1,1	3	90	66	55
806/A T	16.000	0,75	2,2	90	68	65
806/B T	19.000	1,1	3	90	68	68
806/C T	22.500	1,5	4	100	69	75
906/A T	25.000	1,5	4	100	75	98
906/B T	29.000	2,2	5	112	75	105
906/C T	32.000	2,2	5	112	75	105
1006/A T	27.000	1,5	4	100	79	130
1006/B T	33.000	2,2	5	112	79	142
1006/C T	41.000	3	7	132	80	155
1126/B T	45.000	4	9	132	83	165
1126/C T	54.000	5,5	12	132	83	175
1256/B T	55.000	7,5	15	160	87	310
1256/C T	70.000	11	22	160	88	340
1256/D T	85.000	11	22	160	88	340
1406/A T	115.000	18,5	35	200	91	540

4 POLA / POLES (1500 RPM) TROFAZNA / THREE-PHASE (3Ph-400V 50Hz)

Modello Model	Portata Flow rate (m ³ /h)	Pm (kW)	In max (A)	Mot. (H)	Lp (dB(A))	Kg
314/A T	2.300	0,09	0,4	56	52	15
354/A T	3.200	0,09	0,4	56	56	16
404/A T *	4.000	0,12	0,5	63	61	18
404/B T	5.200	0,18	0,6	63	62	19
454/A T	6.500	0,25	0,8	71	65	23
454/B T	7.600	0,37	1,2	71	66	24
504/A T *	8.000	0,37	1,2	71	68	27
504/B T	9.000	0,55	1,6	80	69	28
564/A T *	10.000	0,55	1,6	80	71	37
564/B T	12.500	0,75	2	80	72	39
634/A T	13.000	0,75	2	80	75	46
634/B T	16.000	1,1	2,8	90	76	50
634/C T	17.000	2,2	5	100	76	58
714/A T	17.000	1,5	3,5	90	77	60
714/B T	20.500	2,2	5	100	77	65
714/C T	18.500	2,2	5	100	77	65
714/D T	23.500	3	6,5	100	79	70
804/A T	24.000	3	6,5	100	78	80
804/B T	29.000	4	8,2	112	79	90
804/C T	35.000	5,5	11	132	80	105
804/D T	40.000	7,5	15	132	80	110
904/A T	38.000	5,5	11	132	85	130
904/B T	43.000	7,5	15	132	86	135
904/C T	47.000	7,5	15	132	86	135
904/D T	52.500	9,2	18	132	86	140
1004/A T	41.000	5,5	11	132	88	160
1004/B T	50.000	7,5	15	132	89	165
1004/C T	59.000	11	21	160	89	260
1004/D T	65.000	15	27,8	160	90	280
1004/E T	72.500	18,5	32,6	180	90	315
1124/A T	80.000	18,5	32,6	180	93	375
1124/B T	87.000	22	38,8	180	94	405
1124/C T	100.000	30	53	200	94	470
1254/A T	95.000	22	38,8	180	97	440
1254/B T	110.000	30	53	200	98	495
1254/C T	125.000	37	64	225	98	590

8 POLA / POLES (750 RPM) TROFAZNA / THREE-PHASE (3Ph-400V 50Hz)

Modello Model	Portata Flow rate (m ³ /h)	Pm (kW)	In max (A)	Mot. (H)	Lp (dB(A))	Kg
568/A T	6.000	0,12	0,7	71	56	34
638/A T *	8.000	0,18	0,8	80	60	41
718/A T *	11.000	0,37	1,5	90	61	53
808/A T *	10.000	0,37	1,5	90	61	66
808/B T *	13.000	0,37	1,5	90	62	66
908/A T	17.000	0,75	2,3	100	69	94
908/B T	20.500	0,75	2,3	100	69	94
1008/A T	20.500	0,75	2,3	100	74	124
1008/B T	25.000	1,1	3,4	100	74	127
1128/C T	40.500	2,2	5,5	132	77	157
1258/A T	34.500	2,2	5,5	132	81	180
1258/B T	43.000	3	7,3	132	81	190
1258/C T	52.000	4	9,3	160	82	280
1258/D T	59.000	4	9,3	160	82	280
1408/A T	87.000	7,5	14,7	160	85	395

Tolerancije: aerodinamičke performanse i buka su unutar tolerancija navedenih u DIN 24166, klasa 2. * Samo za tržište van Evrope.

TOLERANCES: performances and sound power levels within the tolerances allowed by the DIN 24166 standard for Class 2. / * Only for non European market.

DUCT-M

PERFORMANSE - PERFORMANCES

1 mm H₂O = 9,8 Pa

Performanse prikazane na dijagramima odnose se na vazduh na temperaturi od 15 °C i nadmorskoj visini od 0 m., a dobijeni su u instalacijama tipa "D" u nedostatku mreže i pribora.

Performance shown in the selection diagrams refer to the airflow from impeller to air at 15°C temperature and 0 mt a.s.l. altitude, and they were obtained in installation type "D" with no grid nor accessories.

DUCT-M 310

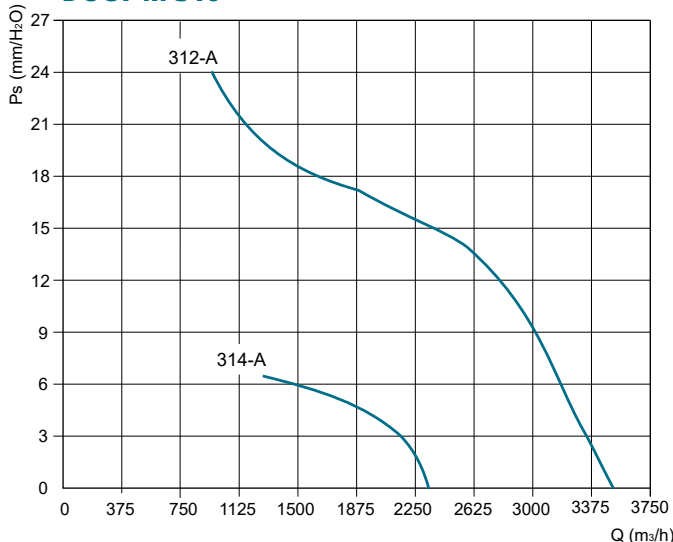

DUCT-M 350

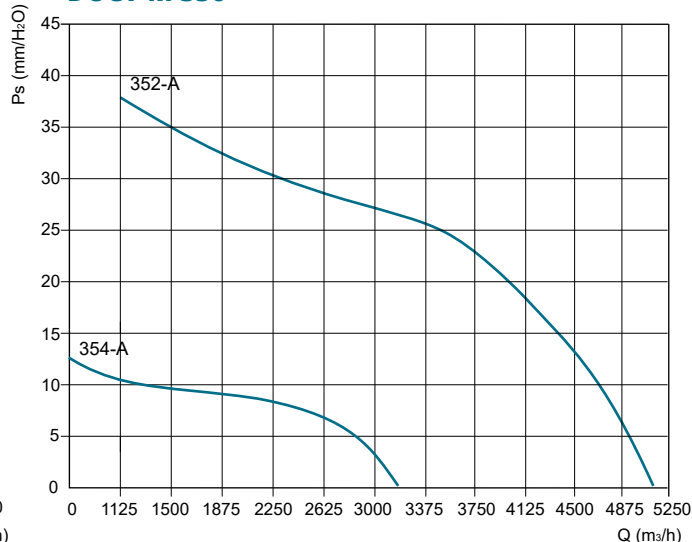

DUCT-M 400

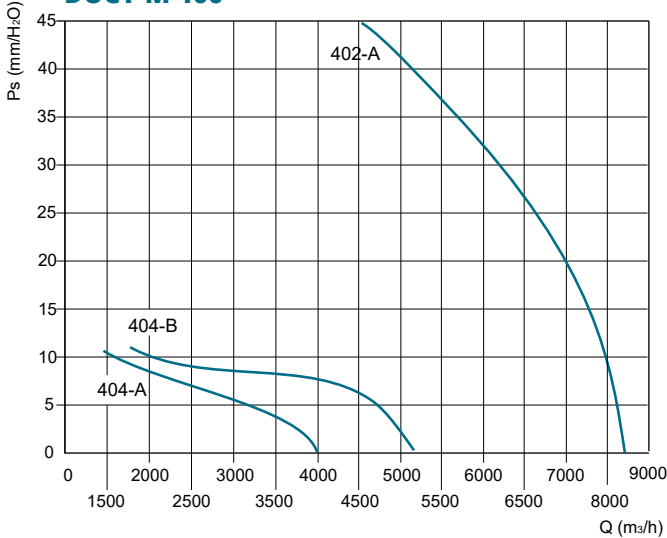

DUCT-M 450

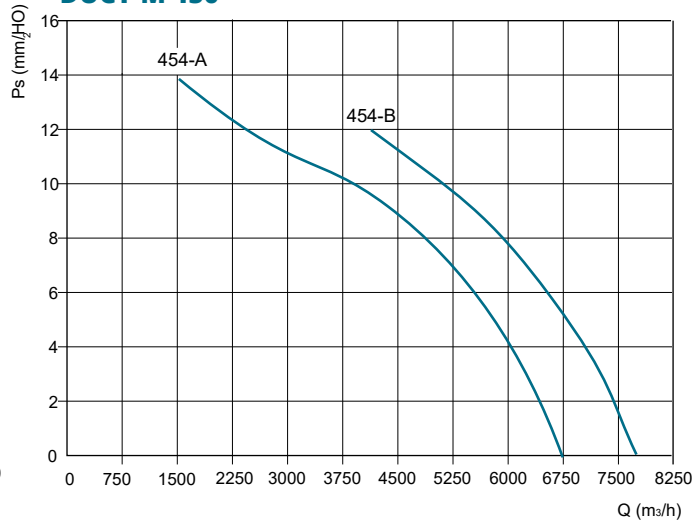

DUCT-M 500

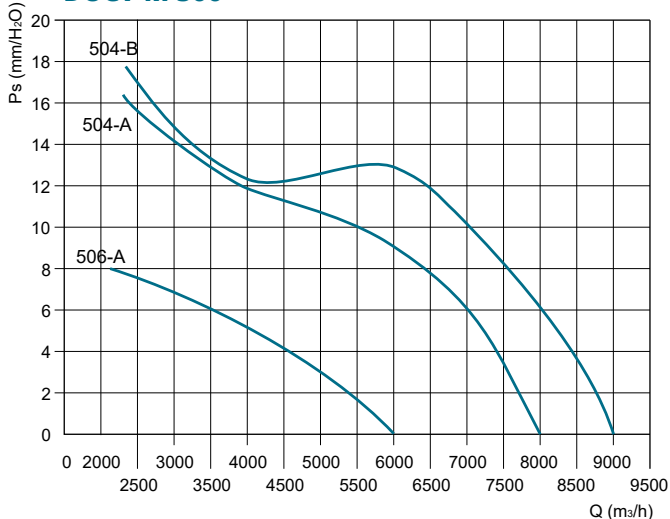

DUCT-M 560

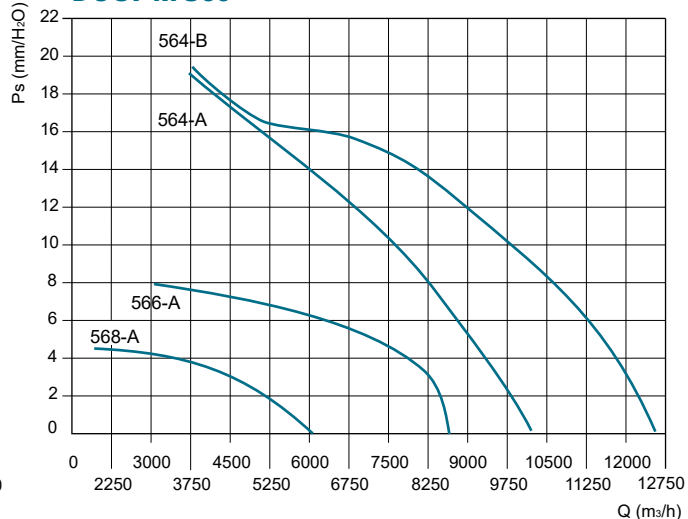

DUCT-M

PERFORMANSE - PERFORMANCES

1 mm H₂O = 9,8 Pa

Performanse prikazane na dijagramima odnose se na vazduh na temperaturi od 15 °C i nadmorskoj visini od 0 m. , a dobijeni su u instalacijama tipa "D" u nedostatku mreže i pribora.

Performance shown in the selection diagrams refer to the airflow from impeller to air at 15°C temperature and 0 mt a.s.l. altitude, and they were obtained in installation type "D" with no grid nor accessories.

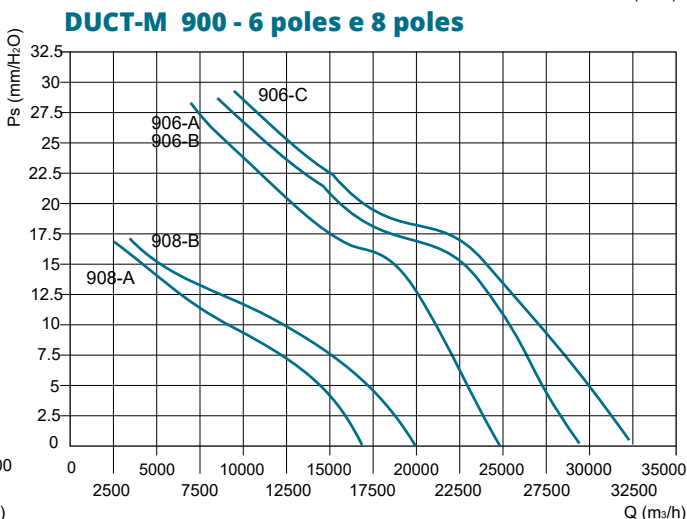
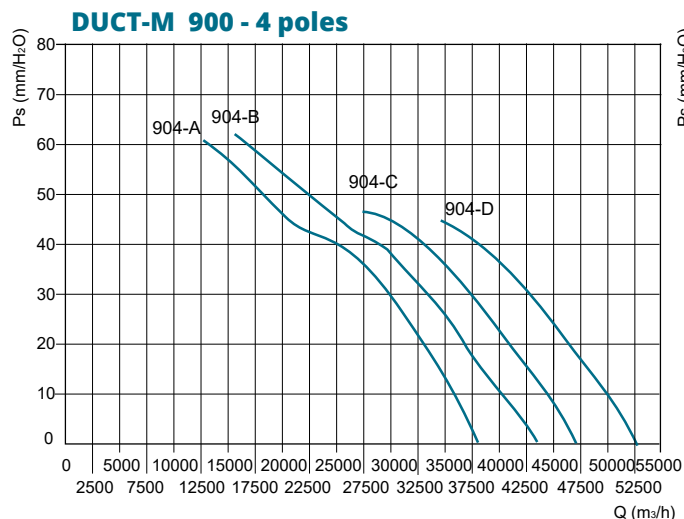
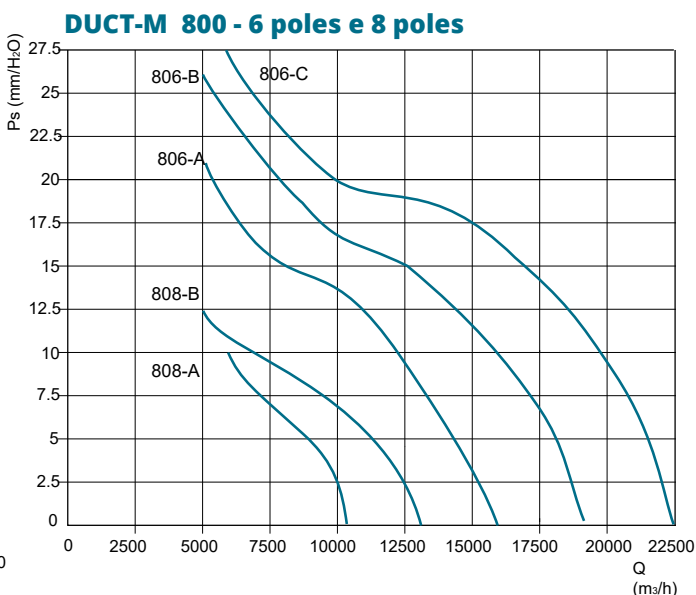
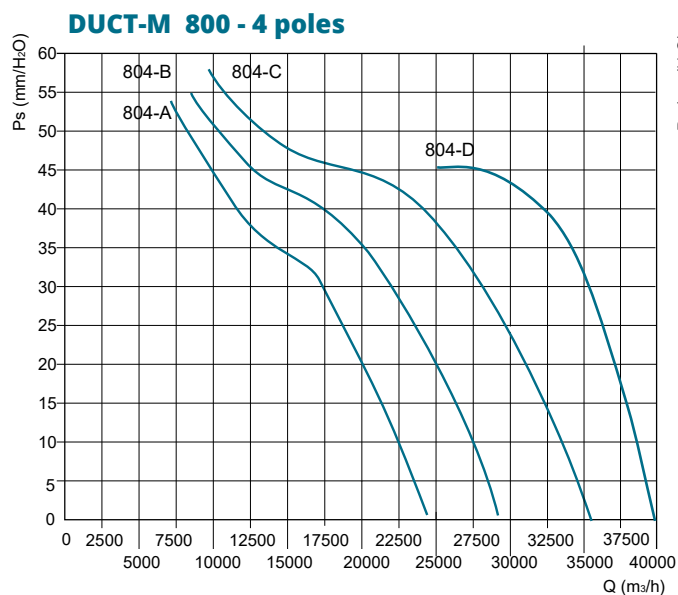
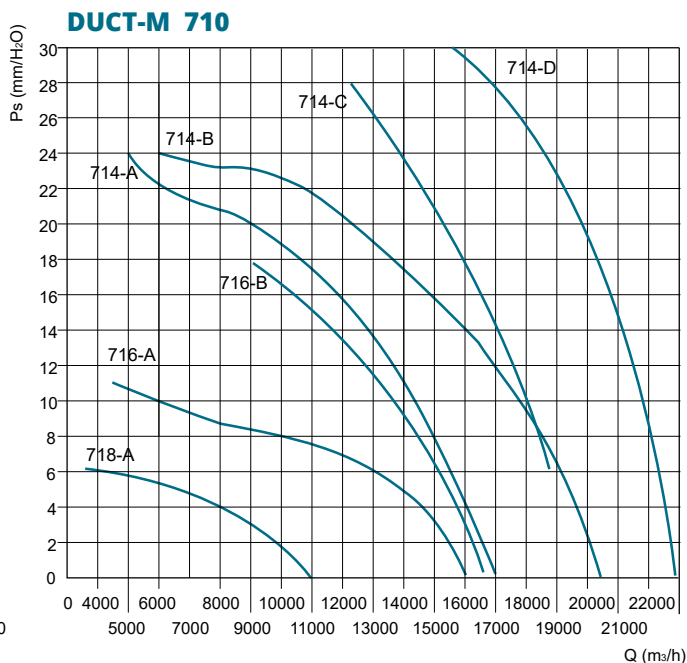
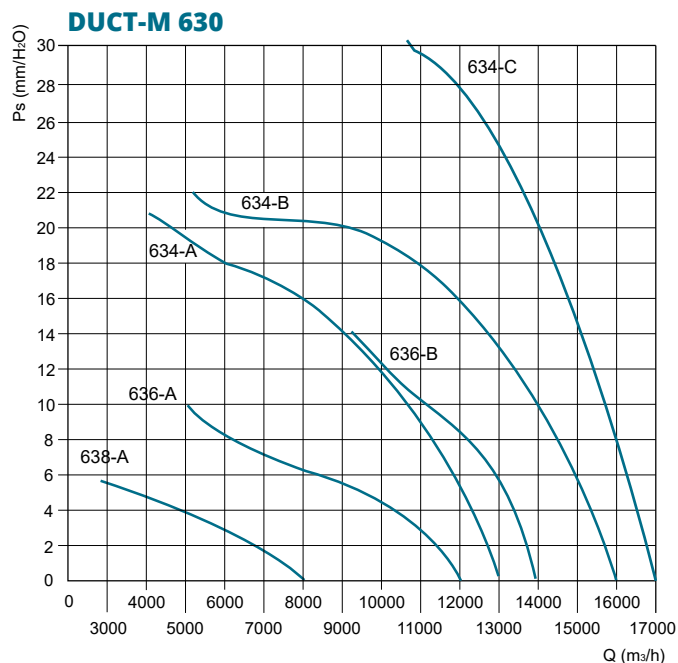

DUCT-M

PERFORMANSE - PERFORMANCES

1 mm H₂O = 9,8 Pa

Performanse prikazane na dijagramima odnose se na vazduh na temperaturi od 15 °C i nadmorskoj visini od 0 m., a dobijeni su u instalacijama tipa "D" u nedostatku mreže i pribora.

Performance shown in the selection diagrams refer to the airflow from impeller to air at 15°C temperature and 0 mt a.s.l. altitude, and they were obtained in installation type "D" with no grid nor accessories.

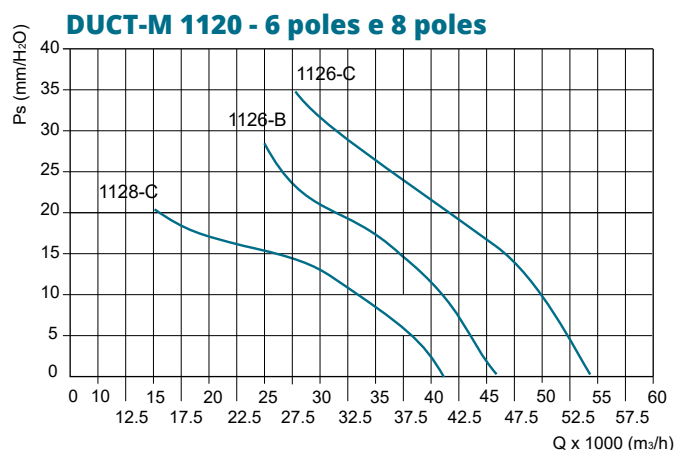
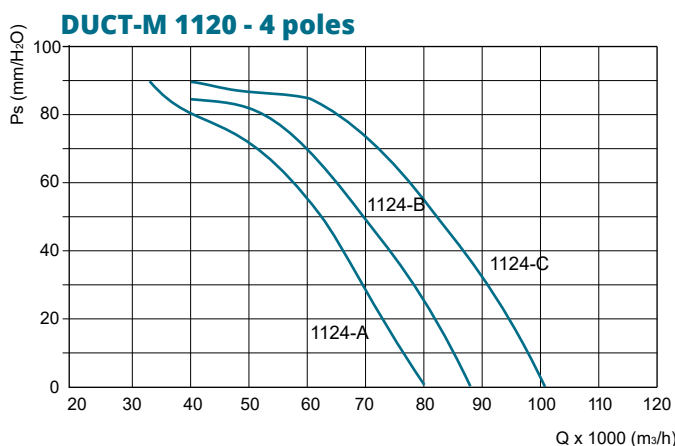
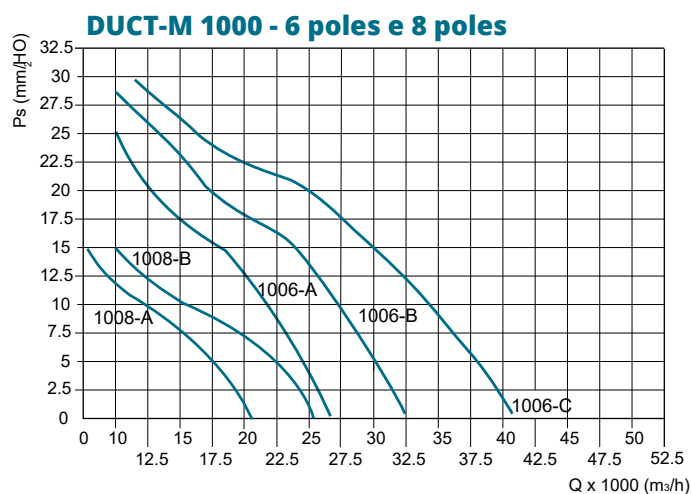
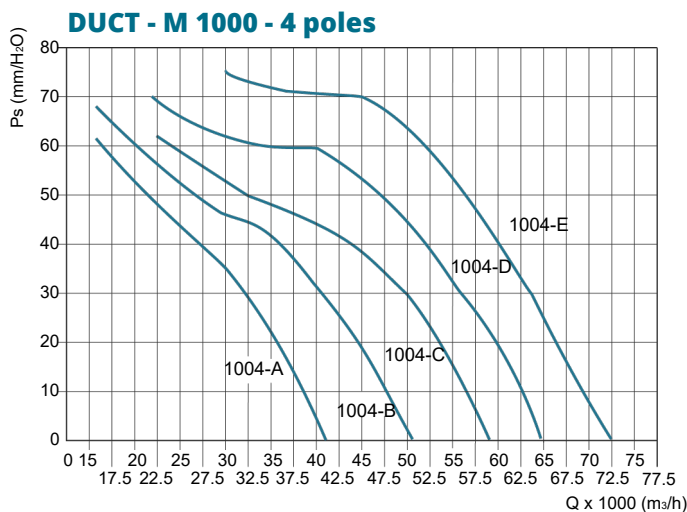

Ova linija se sastoji od 15 veličina sa prečnikom impelera od 310 do 1600 mm.

This line consists of 15 sizes with impeller diameter from 310 up to 1600 mm.

DUCT-M

PERFORMANSE - PERFORMANCES

1 mm H₂O = 9,8 Pa

Performanse prikazane na dijagramima odnose se na vazduh na temperaturi od 15 °C i nadmorskoj visini od 0 m., a dobijeni su u instalacijama tipa "D" u nedostatku mreže i pribora.

Performance shown in the selection diagrams refer to the airflow from impeller to air at 15°C temperature and 0 mt a.s.l. altitude, and they were obtained in installation type "D" with no grid nor accessories.

DUCT-M 1250- 4 poles

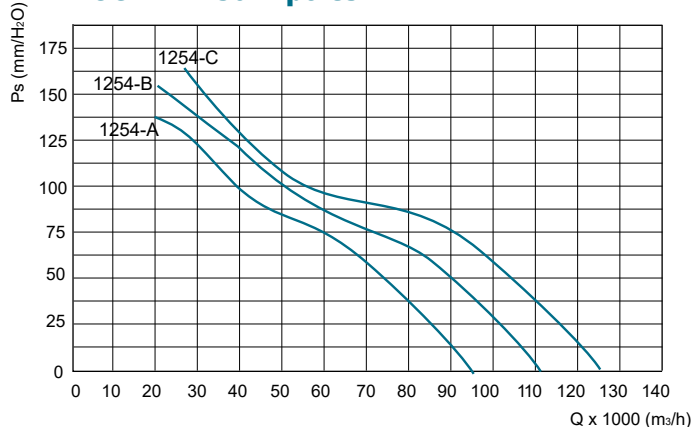

DUCT-M 1250 - 6 poles

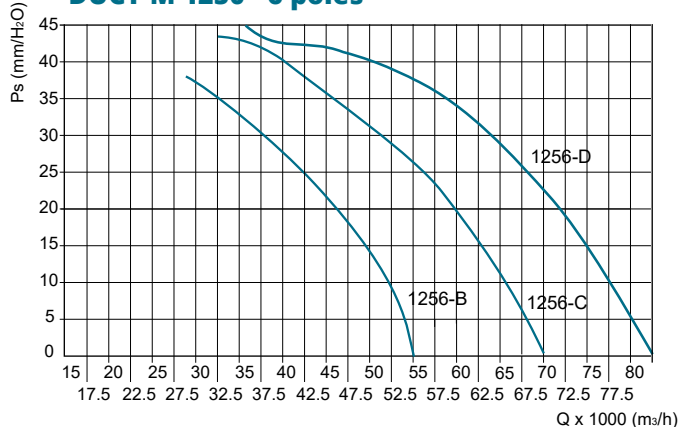

DUCT-M 1250 - 8 poles

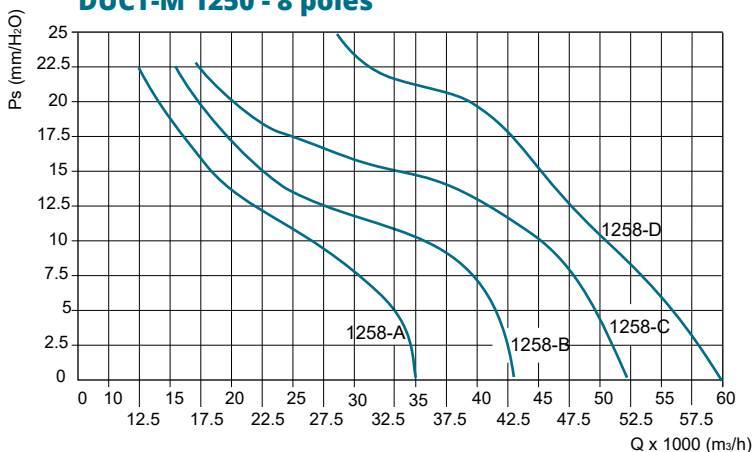

DUCT-M 1400 - 6 poles

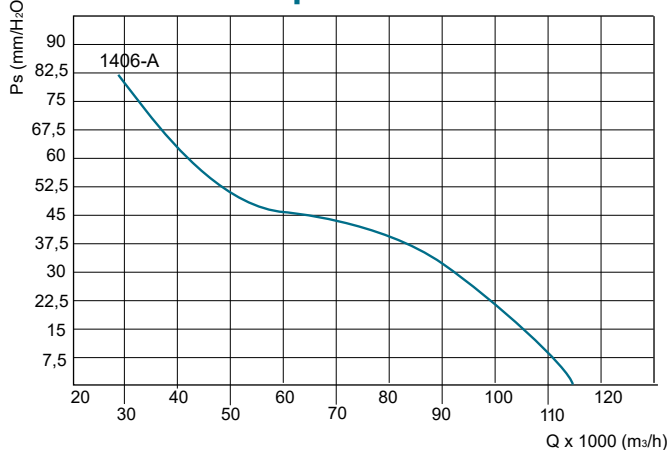

DUCT-M 1400 - 8 poles

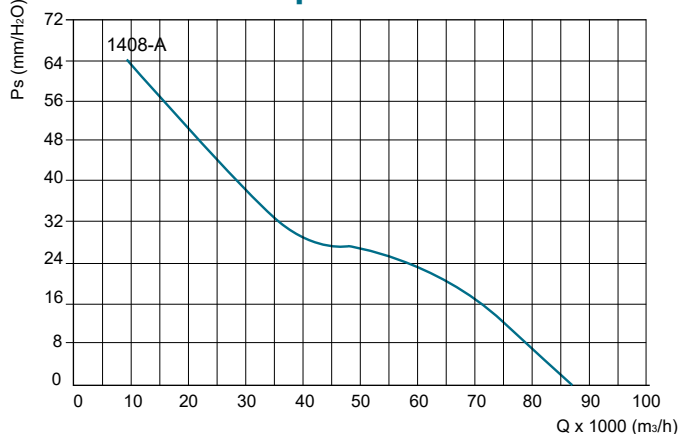

DUCT-M**NIVO BUKE- NOISE LEVEL**

2 POLA / 2 POLES

Modello Model	63	125	250	500	1k	2k	4k	8k	Total
	Hz								
312/A - 0,25 KW	52	61	62	63	64	62	56	47	70
352/A - 0,55 KW	56	65	67	67	68	66	60	51	74
402/A - 1,1 KW	61	70	72	72	73	70	65	56	79

4 POLA / 4 POLES

Modello Model	63	125	250	500	1k	2k	4k	8k	Total
	Hz								
314/A - 0,12 KW	34	43	45	46	47	44	38	29	52
354/A - 0,12 KW	38	47	49	50	51	48	42	33	56
404/A - 0,12 KW	43	52	54	55	56	53	47	38	61
404/B - 0,18 KW	44	53	55	55	56	53	48	38	62
454/A - 0,25 KW	47	56	58	59	60	57	51	42	65
454/B - 0,37 KW	48	57	59	59	60	57	52	42	66
504/A - 0,37 KW	50	59	61	61	63	59	54	44	68
504/B - 0,55 KW	54	62	64	65	66	63	57	48	71
564/B - 0,75 KW	54	63	65	66	67	64	58	49	72
634/A - 0,75 KW	57	66	68	69	70	67	61	52	75
634/B - 1,1 KW	53	67	69	69	70	67	62	52	76
634/C - 2,2 KW	53	66	69	69	70	67	62	52	76
714/A - 1,5 KW	59	68	70	70	71	68	63	53	77
714/B - 2,2 KW	60	68	70	71	72	69	63	54	77
714/C - 2,2 KW	59	68	70	70	71	68	63	53	77
714/D - 3 KW	59	68	70	71	72	69	63	54	77
804/A - 3 KW	60	70	71	72	73	70	64	55	78
804/B - 4 KW	60	70	71	72	73	70	64	55	79
804/C - 5,5 KW	61	70	72	73	74	71	65	56	80
804/D - 7,5 KW	61	70	72	73	74	71	65	56	80
904A/ - 5,5 KW	67	76	78	79	80	77	71	62	85
904/B - 7,5 KW	68	77	79	79	80	77	72	62	86
904/C - 7,5 KW	68	77	79	79	80	77	72	62	86
904/D - 9,2 KW	68	77	79	79	80	77	72	62	86
1004/A - 5,5 KW	70	79	82	82	83	80	74	65	88
1004/B - 7,5 KW	71	80	82	83	84	81	75	66	89
1004/C - 11 KW	71	80	82	83	84	81	75	66	89
1004/D - 15 KW	72	81	83	83	84	81	75	66	90
1004/E - 18,5 KW	72	81	83	83	84	81	76	66	90
1124/A - 18,5 KW	75	84	86	87	88	85	79	70	93
1124/B - 22 KW	76	85	87	87	88	85	80	70	94
1124/C - 30 KW	76	85	87	87	88	85	80	70	94
1254/A - 22 KW	79	88	90	91	92	89	83	74	97
1254/B - 31 KW	80	88	91	91	92	89	84	74	98
1254/C - 37 KW	80	88	91	91	92	89	84	74	98



NIVO BUKE - NOISE LEVEL

6 POLA / 2 POLES

Modello Model	63	125	250	500	1k	2k	4k	8k	Total
	Hz								
506/A - 0,18 kW	40	49	51	52	53	50	44	35	58
566/A - 0,25 kW	44	53	55	55	46	54	48	39	62
636/A - 0,37 kW	48	57	59	59	60	57	52	62	66
636/B - 0,75 kW	47	56	58	58	60	57	51	42	65
716/A - 0,75 kW	49	58	60	60	61	58	53	43	67
716/B - 1,1 kW	48	57	57	60	61	58	52	43	66
806/A - 0,75 kW	50	53	61	61	62	59	54	44	68
806/B - 1,1 kW	50	53	61	61	62	52	54	44	68
806/C - 1,5 kW	50	59	63	62	63	60	54	45	69
906/A - 1,5 kW	56	65	63	68	69	66	60	51	74
906/B - 2,2 kW	57	66	68	68	69	66	61	51	75
906/C - 2,2 kW	57	66	67	68	69	66	61	51	75
1006/A - 1,5 kW	61	70	72	72	73	70	65	55	79
1006/B - 2,2 kW	61	70	72	72	73	71	65	56	79
1006/C - 3 kW	61	70	73	73	74	71	65	56	80
1126/B - 4 kW	65	74	76	76	77	74	69	60	83
1126/C - 5,5 kW	68	77	79	80	81	78	72	63	86
1256/B - 7,5 kW	69	78	80	80	81	78	73	63	87
1256/C - 11 kW	70	78	80	81	82	79	73	64	88
1256/D - 11 kW	70	78	80	81	82	79	73	64	88
1406/A - 18,5 kW	73	82	84	84	85	82	77	67	91

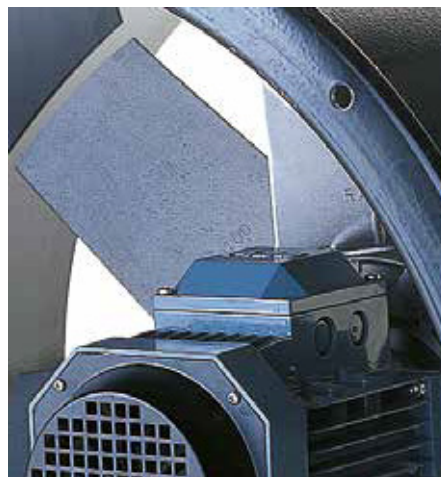

8 POLA / 4 POLES

Modello Model	63	125	250	500	1k	2k	4k	8k	Total
	Hz								
314/A - 0,12 kW	34	43	45	46	47	44	38	29	52
354/A - 0,12 kW	38	47	49	50	51	48	42	33	56
404/A - 0,12 kW	43	52	54	55	56	53	47	38	61
404/B - 0,18 kW	44	53	55	55	56	53	48	38	62
454/A - 0,25 kW	47	56	58	59	60	57	51	42	65
454/B - 0,37 kW	48	57	59	59	60	57	52	42	66
504/A - 0,37 kW	50	59	61	61	63	59	54	44	68
504/B - 0,55 kW	51	60	62	62	63	60	55	45	69
564/A - 0,55 kW	54	62	64	65	66	63	57	48	71
564/B - 0,75 kW	54	63	65	66	67	64	58	49	72
634/A - 0,75 kW	57	66	68	69	70	67	61	52	75
634/B - 1,1 kW	57	65	68	68	69	66	61	51	76
634/C - 2,2 kW	58	66	69	69	70	67	62	52	76
714/A - 1,5 kW	59	68	70	70	71	68	63	53	77
714/B - 2,2 kW	60	68	70	71	72	69	63	54	77
714/C - 2,2 kW	59	68	70	70	71	68	63	53	77
714/D - 3 kW	59	68	70	71	72	69	63	54	77
804/A - 3 kW	60	70	71	72	73	70	64	55	78
804/B - 4 kW	60	70	71	72	73	70	64	55	79
804/C - 5,5 kW	61	70	72	73	74	71	65	56	80
804/D - 7,5 kW	61	70	72	73	74	71	65	56	80
904A/ - 5,5 kW	67	76	78	79	80	77	71	62	85
904/B - 7,5 kW	68	77	79	79	80	77	72	62	86
904/C - 7,5 kW	68	77	79	79	80	77	72	62	86
904/D - 9,2 kW	68	77	79	79	80	77	72	62	86
1004/A - 5,5 kW	70	79	82	82	83	80	74	65	88
1004/B - 7,5 kW	71	80	82	83	84	81	75	66	89
1004/C - 11 kW	71	80	82	83	84	81	75	66	89

Upozorenje: nivo zvučnog pritiska se odnosi na omnidirekciono merenje u slobodnom polju na 3 m od ventilatora sa kanalnim usisom i isporukom.

ATTENTION: sound pressure level is measured in free field at 3 m from the fan, in any direction, with ducted inlet and outlet.

DUCT-M

DIMENZIJE - DIMENSIONS

Modello Model	A	Mot.(H)	B(Ms)	B1(Mm)	B2(ML)	C	D	E (Ms)	E (Mm)	F	G
31	310	5663	260	260	400	355	390	430	330	8	10
35	360	5671	260	260	400	395	430	450	350	8	10
40	410	6380	260	260	400	450	490	470	370	8	12
45	460	7180	260	260	450	500	540	430	380	8	12
50	510	7180	260	260	450	560	595	440	380	12	12
56	570	7190	260	260	450	620	655	450	410	12	12
63	640	90100	260	350	500	690	725	470	470	12	12
71	710	90112	260	350	600	770	805	490	490	16	12
80	810	90132	350	450	600	860	900	600	600	16	12
90	910	100132	350	450	700	970	1010	600	600	16	16
100	1010	100160		560	800	1070	1110		830	16	16
		180		800	900				900		
		132		560	800				710		
112	1130	160		800	900	1190	1230		860	20	16
		180200		800	1000				960		
		225									
		250			1150						
125	1260	132		560	800	1320	1360		720	20	16
		160		800	900				860		
		180200			1000				980		
		225							1000		
		250280			1150						
140	1400	160225			1000	1470	1520			20	16
		250280			1150						
160	1610	160225			1000	1680	1730			24	20
		250280			1150						

Dimenzionalne tolerancije u ± 5 mm - Dimensional tolerances ± 5 mm

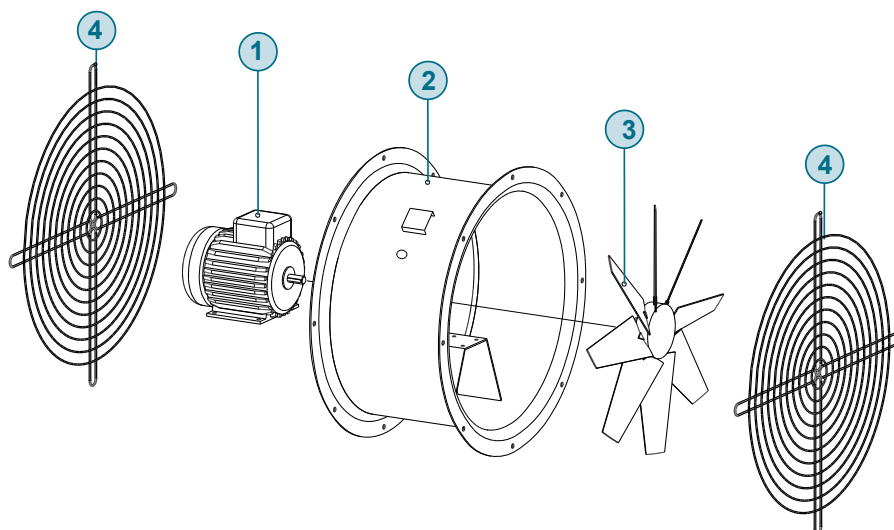
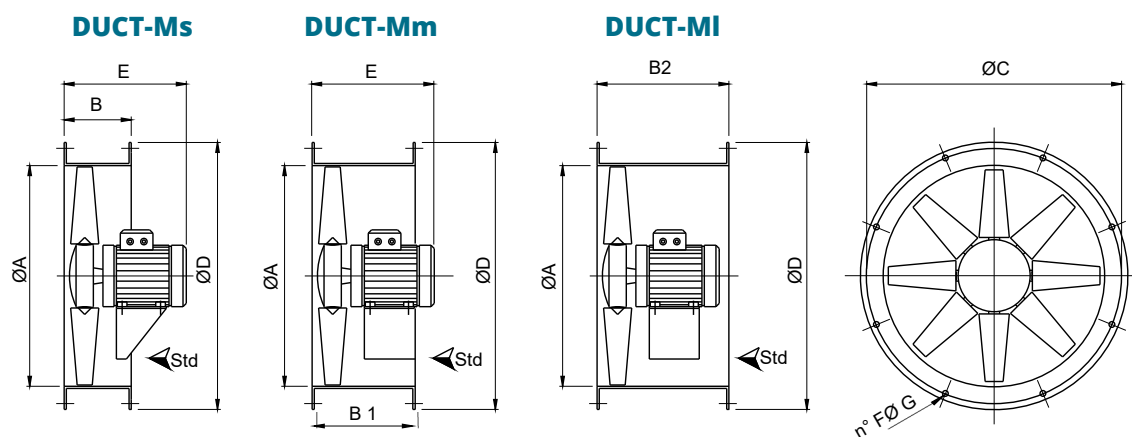

- 1 Motor - Motor
- 2 Transporter - Casing
- 3 Girante - Impeller
- 4 Mrežni "pribor"
(obavezno za slobodan vazduh)
Grid "accessory"
(mandatory for free air)